

LA-3779-MS

C.3

LOS ALAMOS SCIENTIFIC LABORATORY
of the
University of California
LOS ALAMOS • NEW MEXICO

Press-Formed Explosive Charges
for the
BLU-26/B Fragmentation Bomb



UNITED STATES
ATOMIC ENERGY COMMISSION
CONTRACT W-7405-ENG. 36

LEGAL NOTICE

This report was prepared as an account of Government sponsored work. Neither the United States, nor the Commission, nor any person acting on behalf of the Commission:

A. Makes any warranty or representation, expressed or implied, with respect to the accuracy, completeness, or usefulness of the information contained in this report, or that the use of any information, apparatus, method, or process disclosed in this report may not infringe privately owned rights; or

B. Assumes any liabilities with respect to the use of, or for damages resulting from the use of any information, apparatus, method, or process disclosed in this report.

As used in the above, "person acting on behalf of the Commission" includes any employee or contractor of the Commission, or employee of such contractor, to the extent that such employee or contractor of the Commission, or employee of such contractor prepares, disseminates, or provides access to, any information pursuant to his employment or contract with the Commission, or his employment with such contractor.

All LA...MS reports are informal documents, usually prepared for a special purpose and primarily prepared for use within the Laboratory rather than for general distribution. This report has not been edited, reviewed, or verified for accuracy. All LA...MS reports express the views of the authors as of the time they were written and do not necessarily reflect the opinions of the Los Alamos Scientific Laboratory or the final opinion of the authors on the subject.

LOS ALAMOS SCIENTIFIC LABORATORY
of the
University of California
LOS ALAMOS • NEW MEXICO

Report written: August 1967

Report distributed: October 31, 1967

Press-Formed Explosive Charges
for the
BLU-26/B Fragmentation Bomb

by

T. M. Benziger



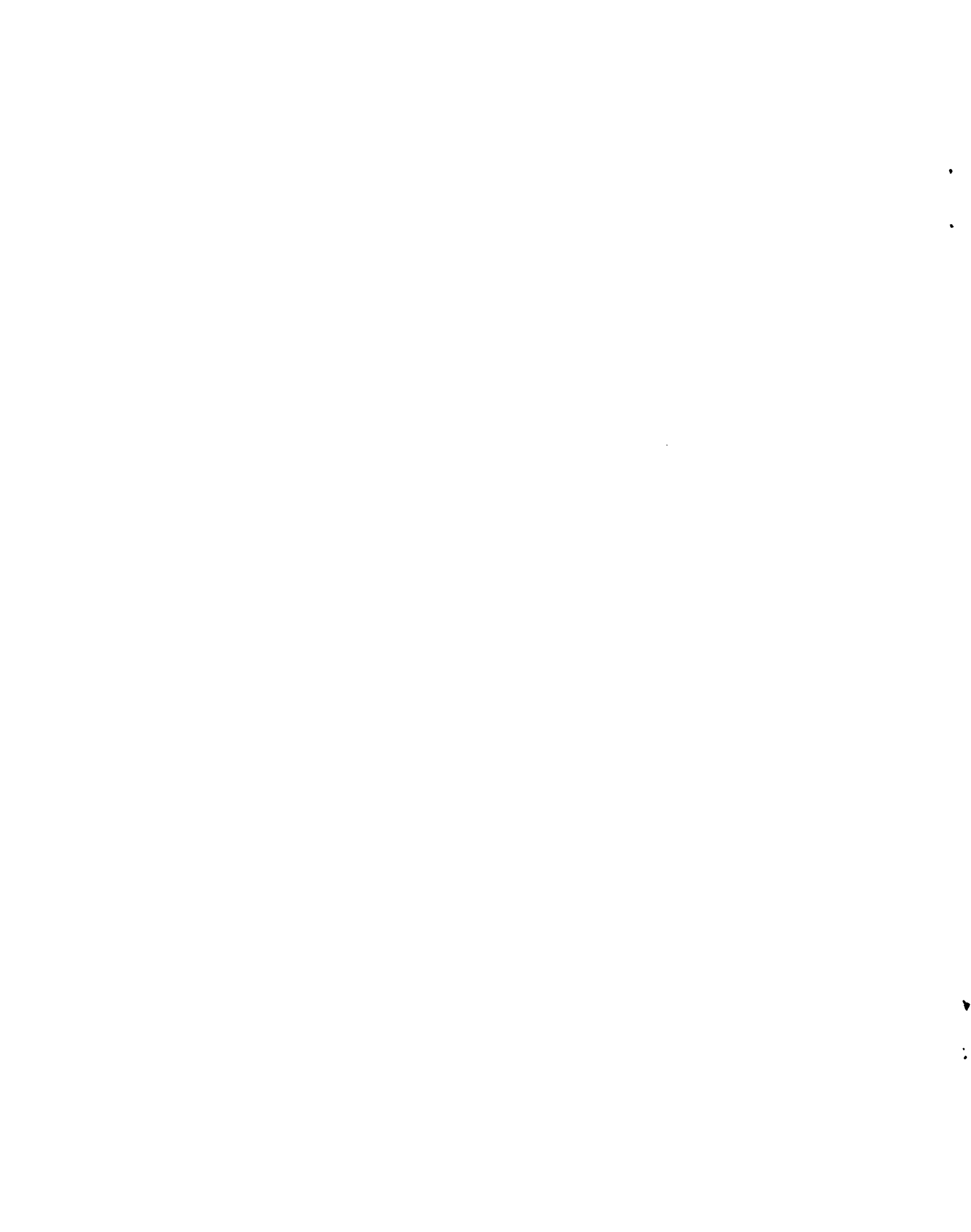

PRESS-FORMED EXPLOSIVE CHARGES FOR THE BLU-26/B FRAGMENTATION BOMB

by

T. M. Benziger

ABSTRACT

Two methods of press-forming the explosive charge for the BLU-26/B fragmentation bomb were developed. In one method the HE hemispheres were pressed to final shape in an automatic pellet press for assembly in the metal case. In the other method the HE hemispheres were pressed to final shape directly into the case. Our experience indicates that the pellet-press procedure is the preferred method and that, with minor changes in the case design, it would provide a suitable alternate for the cast-loading process now being used.

The preparation and properties of the explosive compositions developed for this application are briefly described.

I. INTRODUCTION

At the request of the Air Force Armament Laboratory, Eglin Air Force Base, Florida, this Laboratory agreed to investigate the feasibility of pressing the BLU-26/B explosive charge. The BLU-26/B is a small bomb, three inches in diameter, consisting of two die-cast (steel ball-aluminum matrix) hemispheres crimped together and loaded with a high explosive (Fig. 1). The fuze is armed by rotation and actuated by ground impact. At present these bombs are cast-loaded with 70/30-Cyclotol. The possible advantages of molding over casting would be the elimination of the cooling cycle and of the machining of the recess for the fuze. In addition, pressing appears more amenable to automation than does a cast-loading process.

Two methods were studied, both involving the compression molding of an explosive charge complete with fuze recess. The first consisted of pressing the explosive hemispheres using an automatic pellet-press. The second method involved pressing the explosive powder directly into the metal halves of the bomb. A standard hydraulic press was used for this operation.

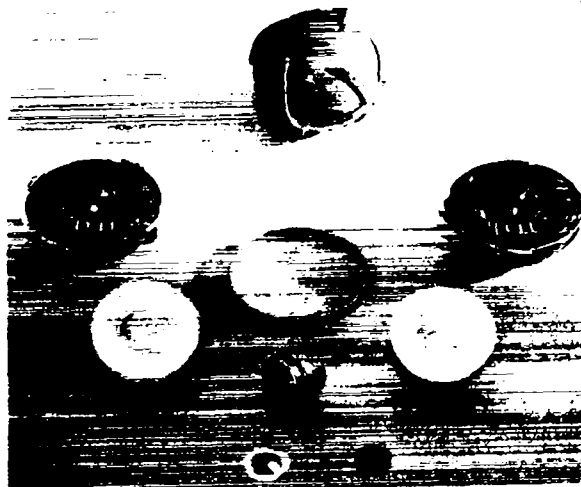

Figure 1

II. EXPLOSIVES

A. General Description

It was required that the explosive used be inexpensive and readily available, in addition to having acceptable loading, sensitivity, stability, and performance characteristics. Extensive local

experience with HMX/wax/Elvax mixtures suggested that an RDX/wax/Elvax composition, with or without added aluminum, was most likely to meet these requirements. Three such mixtures were subjected to preliminary sensitivity and performance tests. Their compositions were as follows:

91/8.1/0.9 - RDX/B²-170 wax/Elvax 460
94/5.4/0.6 - RDX/B²-170 wax/Elvax 460
74/20/5.4/0.6 - RDX/Al/B²-170 wax/Elvax 460

The preliminary tests indicated that these compositions, in comparison with 70/30-Cyclotol, were less sensitive to impact, were more sensitive to initiation by shock (as from a booster pellet), and gave the same low-order explosion as Cyclotol when cased and subjected to .50 cal armor-piercing bullet fire. Their performance, as measured in an arena test conducted by Eglin AFB, was comparable to that of Cyclotol, with the aluminized composition possibly having a slight edge. It was primarily on this basis that, at Eglin's request, the aluminized explosive was used in our subsequent development work.

The modifier, Elvax 460, used with the wax binder was necessary to prevent sticking of the composition to the punch surfaces. It is an ethylene-vinyl acetate copolymer that is quite compatible with waxes and contains the polar group necessary for wetting RDX. It strengthens the wax appreciably and increases the cohesive strength of the explosive.

All three compositions are made by the standard slurry process used in the manufacture of plastic-bonded explosives. Details on the preparation of the aluminized composition, and tentative specifications for it, are as follows.

B. Preparation

Preparation of the explosive involves the following steps:

- a) making a slurry of RDX in hot water;
- b) adding a lacquer consisting of the binder (wax and Elvax resin), the aluminum powder, and toluene as the solvent;
- c) heating and agitating the slurry until the solids and binder agglomerate in the form of small spherical particles;

- d) removing most of the solvent by azeotropic distillation;
- e) cooling the slurry and filtering off the product;
- f) drying the explosive.

A typical pilot plant preparation (250-lb scale) is carried out in an agitated, 200-gal reactor in the following manner:

The reactor is charged with 600 lb of water, 139 lb of coarse RDX, and 46 lb of fine RDX. The contents are brought to 90°C and held at that temperature for one hour. The temperature is then lowered to 80°C.

A lacquer containing the other ingredients is then added to the reactor. The lacquer is at a temperature of 70°C upon addition. It is prepared in a Cowles dissolver and consists of 13.5 lb of wax, 1.5 lb of Elvax resin, 50 lb of aluminum powder, and 20 lb of toluene.

After about ten minutes, when the ingredients have agglomerated into small particles, the reactor temperature is raised to distill off the toluene-water azeotrope. Heating of the reactor is continued until the temperature is about 2°C above the boiling point of the azeotrope.

The reactor contents are then cooled to 40°C and filtered in a pan filter. The molding powder is dried in a forced draft oven for 16 hours at 60°C.

C. Tentative Specifications

1. Composition

RDX	74 ± 1 w/o
Aluminum	20 ± 1
Wax	5.4 ± 0.4
Elvax #460	0.6 ± 0.05

2. Raw Materials

RDX
3 parts Type B, Class G (coarse)
(Mil-R-398C)
1 part Type B, Class E (fine)
(Mil-R-398C)
Holston Defense Corporation

Aluminum
Atomized aluminum powder, Type III,
Grade F, Class 6 (Mil-A-512A)
Reynolds Metals Company #120 atomized

Wax
Be Square 170 microcrystalline wax
Bareco Wax Division of Petrolite Co.

Elvax #460

Ethylene-vinyl acetate copolymer
E. I. du Pont de Nemours and Co., Inc.

3. Molding Powder

Particle Size

Minimum of 95% through 18 mesh screen
Minimum of 90% retained on 45 mesh screen

Bulk Density

Typical value of 1.0 gm/cc
± 0.5% maximum spread in duplicate samples

Volatiles

Less than 0.06 w/o loss upon heating for 16 hr/60°C, forced-draft oven

D. Inert

An inert composition was developed for use in press setup and initial studies. It was made by the slurry process and consisted of 85/13.5/1.5 - graphite/B²-170 wax/Elvax 460. The graphite was a flour type, 50% through 200 mesh (Great Lakes Carbon Co., #1008).

III. PELLET-PRESS PROCEDURE

The press used in this study is a toggle-type tablet press (Fig. 2) with a maximum load capacity of 100 tons. It is equipped with a gas-loaded pressure equalizer which permits pressing at a constant predetermined pressure within a 1/4 in. stroke cushion limit. The moving (top) hemispherical punch is adjustable as to stroke. The lower punch, forming the equatorial face of the piece, is adjustable as to bottom position and stroke, and also acts to eject the finished piece. A core rod, which passes through the lower punch, is used to form the fuze cavity. It is adjustable and attached to the table frame. The die cavity is loaded through a moving hopper which also acts to discharge the previously formed piece.

The die employed is shown in Fig. 3. Since the sharp edge on a truly hemispherical punch would be much too weak, the equatorial surface of this punch was ground back to give 0.010 in. of wall thickness at the leading edge. The die produces a hemispherical shape with a short cylindrical section at the equator and a stepped recess in the equatorial plane (Fig. 4).

The loading uniformity was excellent. In a

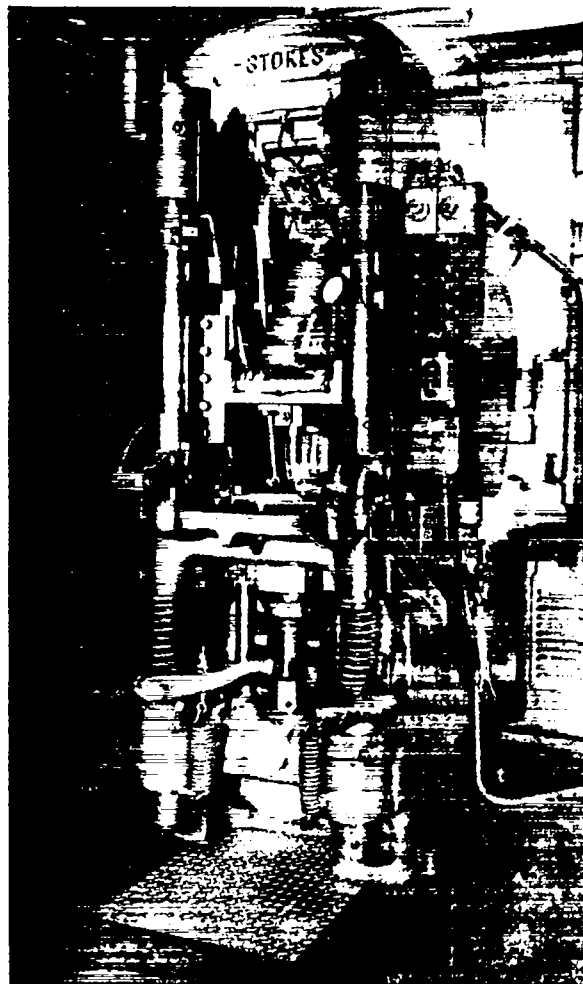

Figure 2

run of 16,000 pieces at a press rate of 450 units per hour, periodic sampling indicated a weight spread of less than ± 1.0%. Dimensions were also quite constant. Measurements on various runs, totaling about 1,000 units, showed a polar height variation of ± 0.004 in., a recess depth variation of + 0.001 in. and an equatorial diameter variation of - 0.000 in. and + 0.002 in. These data were obtained on pieces pressed at 16,000 psi and room temperature to a density of 1.73-1.74 gm/cc.

The pellet weight was a function of the amount of molding powder in the feed hopper until at least one foot of head was used. This weight did not vary significantly with the pressing rate over a range of 2 to 8 hemispheres per minute, nor was

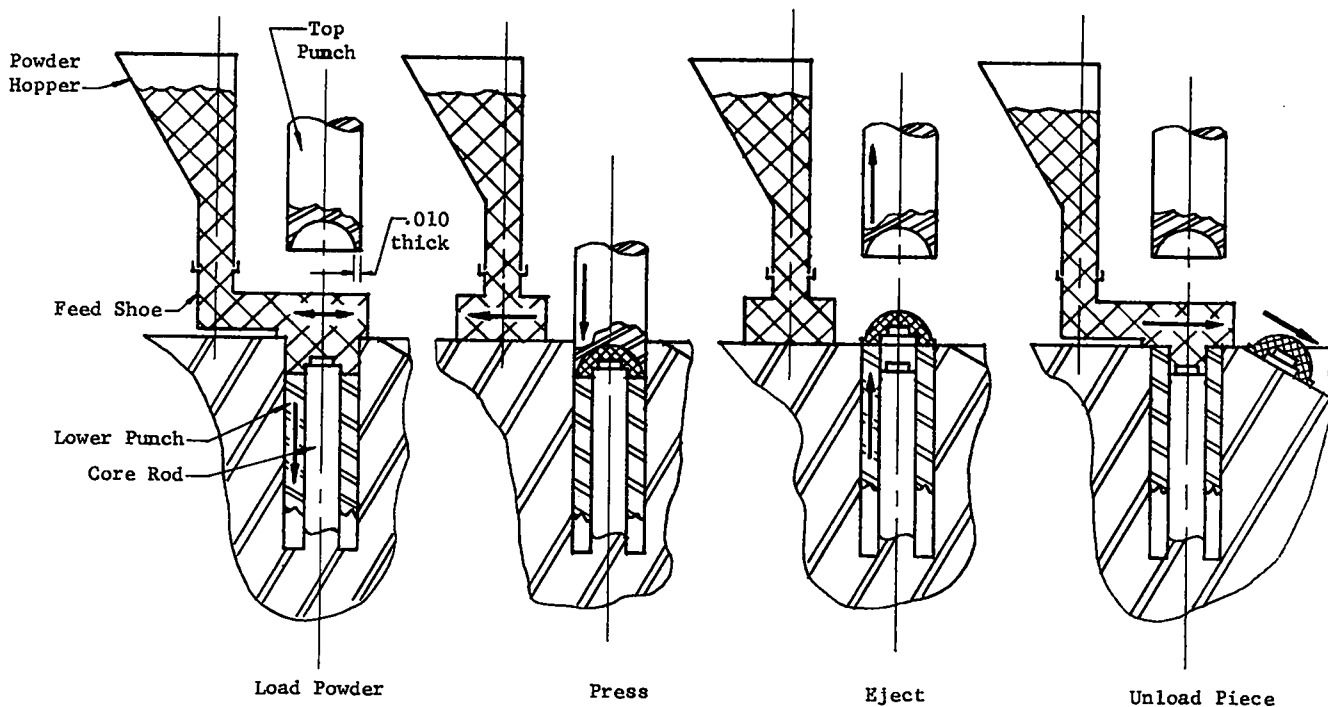

Figure 3

Sticking of the powder to the punch surfaces was not a problem when the proper molding powder was used and the die surfaces had a uniform, highly polished surface. If this problem did occur at higher production rates, it would appear that introducing a slight rotation of the punches in the ejection cycle would be a possible solution.

IV. DIRECT CASE PRESSING

In this method of preparing the explosive charge, the material was pressed directly into the bomb case hemispheres. The process was studied with a four-cavity die set installed in a 150-ton hydraulic press adjusted to give a unit pressure of 20,000 psi. The four cases were held in conforming support cups mounted in a removable tray. The tray was inserted and clamped under four punch and sleeve sets which held the molding powder (Fig. 5). In production, a hydraulic press would not be used; empty cases would be fed to a rotary tablet press for direct case pressing.

A total of 16,000 hemispherical assemblies were made by this method. Since the apparatus used did not include automatic loading equipment, low-

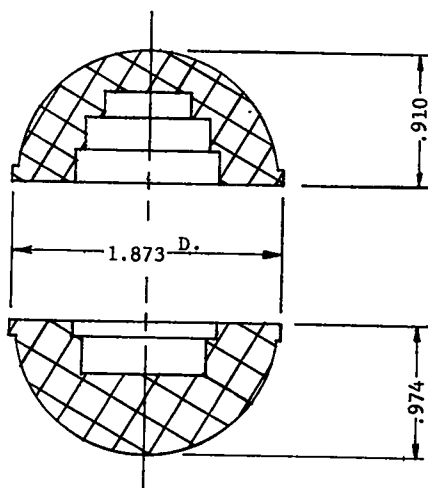

Figure 4

there any indication that a higher rate would cause difficulty.

Molding powder having excessive fines, not meeting the specifications, caused a great deal of trouble with erratic feeding and off-weight charges.

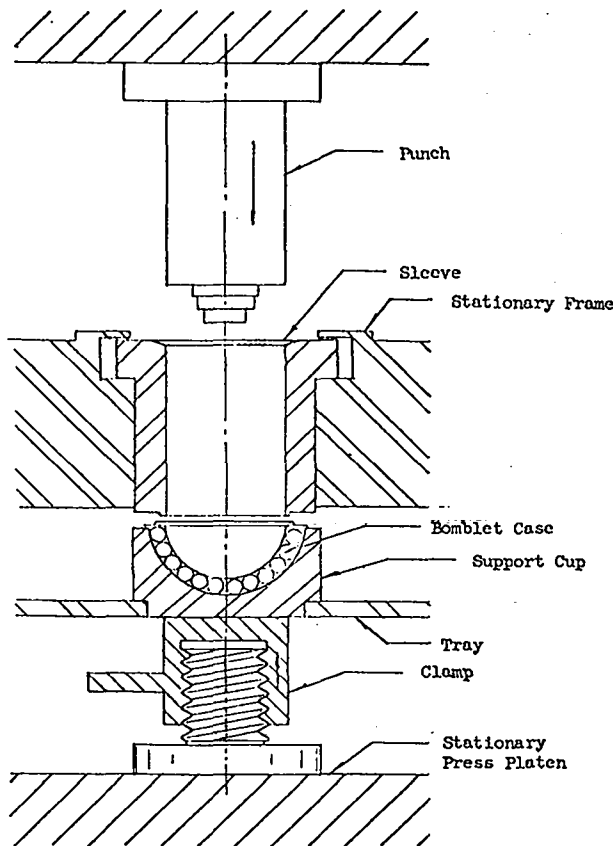

Figure 5

density preforms made on the tablet press were hand-loaded into the die instead of loose molding powder.

On pressed units the dimensional variation of the face of the explosive surface, referenced to the shell, was .008 in. total.

Several difficulties were encountered with this method of pressing. The unit pressure needed for consolidation, 16,000 to 20,000 psi, and the residual force of the explosive against the shell caused the shell to undergo a permanent distortion, + 0.005 in. on the face diameter. If the weight of explosive charged was only slightly above the specified amount, cracking of the case across the flange lip was noted. Flashing across the sleeve-case interface also occurred. Without periodic cleaning of these surfaces, this caused a buildup in the height of the pressed charge over the tolerance limit. These difficulties led us to reject this method in favor of the tablet press method for any volume production.

V. SUMMARY

No attempt was made to evaluate the cost advantage of pressing over casting as a production method. It does appear, however, that the low cycle time, close dimensional control, and amenability to automation of tablet-press forming make this a most attractive system and one that should be pursued by the Air Force.

VI. RECOMMENDATIONS

If press-forming the HLU-26/B charge is adopted:

- 1) The charges should be prepared by the tablet press method.
- 2) The cavities of the case hemispheres should be changed to include a short cylindrical section at the equator to match the press-formed hemispheres. In addition, case tolerances should be referenced to the cavity and held to limits compatible with those found with pressed charges.
- 3) The components should be assembled using a gap-filling adhesive, such as polyurethane, or a low-temperature, hot-melt adhesive, such adhesive to pass HE compatibility tests.

While their investigation was outside the scope of our study, the following changes appear feasible and may offer economies in HLU-26/B production:

- 1) With the close dimensional control of the fuze cavity in pressed charges, the tolerance take-up devices (spring and felt pad) might be eliminated. This change would require a strong booster pellet (plastic bonded), case dimensions which permit full face contact of the explosive hemispheres in assembly, and adhesive bonding of the fuze and pellet in the cavity.
- 2) Since the pressed composition is more sensitive to initiation than 70/30-Cyclotol, it may be possible to eliminate the booster pellet with only a small increase in the amount of material in the fuze lead cup.

VII. ACKNOWLEDGMENT

A number of GMX Division personnel contributed to the work described in this report. The author particularly wishes to acknowledge the contributions of L. E. Edwards, D. L. Upham, R. K. Rohwer, M. J. Urizar, L. W. Hantel, and L. C. Smith (Group Leader) of Group GMX-2; and of H. E. Ballance, J. B. Panowski, H. L. Flaugh, and M. Schwartz of Group GMX-3.